

Ner 12000SLp Installation Manual

Specifications:

1. Compact size and easy to install.
2. Micro controller with door opening delay and door sensor output functions.
3. Suitable for 90° or 180° door open aluminum or wooden doors.
4. Relock function will activate to lock the door automatically (maximum 60 times per session) when the door is not locked properly.
5. Auto adjustable power supply 12/24V.
6. Maximum holding force up to 1200kg. Maximum magnetic distance up to 5mm (@24V).
7. Two long locking holes at cater corners of the armature are able to fine adjust both armature and body when they are installed.

Dimensions:

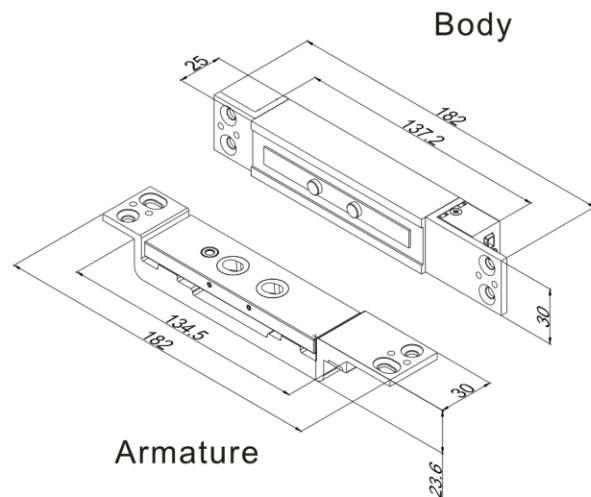
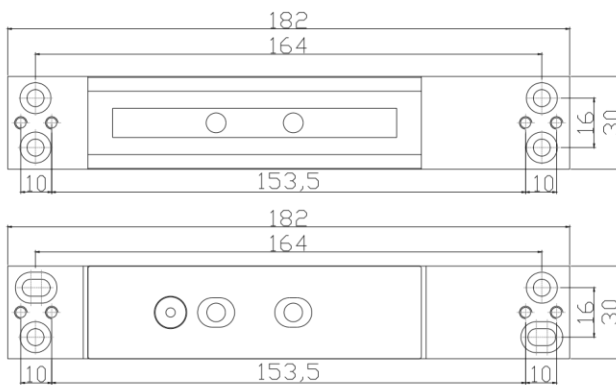

Specifications:

		Notes
Power Input	DC 12V/ DC 24V	±15%
Operation Current	Operation Current:900mA(min) /12VDC Holding Current: 220mA /12VDC	± 5%
	Operation Current:900mA(min) /24VDC Holding Current: 190mA /24VDC	±5%
Lock status output	N.O. & N.C. (Max 24V/1A)	Hall Effect Sensor
Door position output	COM. & N.C. (Max 250mA/30VDC)	
Operation Delay Time	0.5 Sec.- 25 Sec.	
Max. Shear Holding Force	1200Kg(2600Lbs.)	
Operation Temperature	-30°C~50°C	
Warranty	1 year under normal circumstances	
Weight	1.2Kg(2.65Lbs.)	
Magnetic Distance(Max.)	3.0mm @12V / 5.0mm @24V	

Parts:

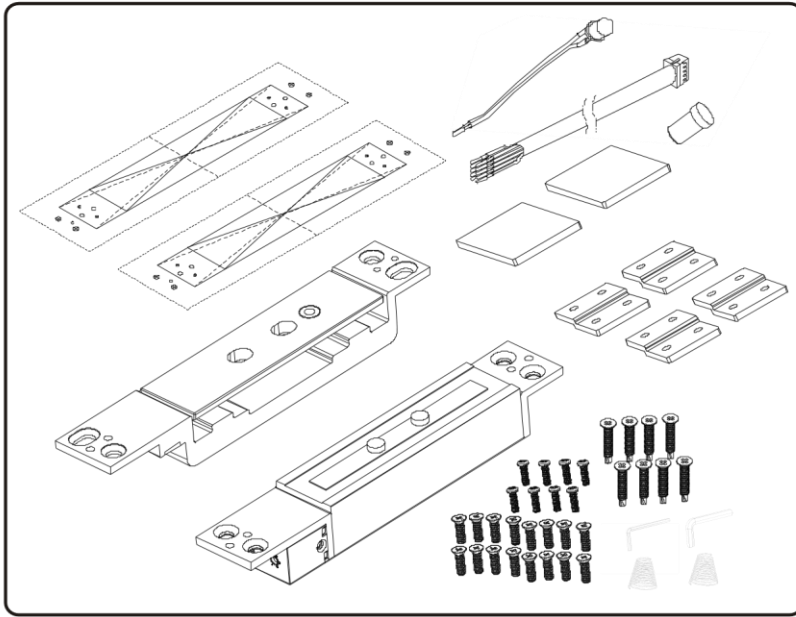

Accessories:

Type	Quantity
Screw M5X8	16
Screw M5X25	8
Screw M4X12	8
M3 Allenkey	1
M6 Allenkey	1
Spring	2
Shims	4
Plastic Board	2
Indicator Light Cap	1
LED Connector	1
10-PIN Connector	1

Connections:

Model Color	10 PIN Connection		
Black	GND	Red	VCC (DC 12~24V)
Brown	Connect status indicator light (blue)	Orange	Connect status indicator light (black)
White	Lock Status Sensor N.O.	Blue	Reserved
Purple	Lock Status Sensor N.C.	Green	Door Positions Sensor COM.
Gray	Lock Status Sensor COM.	Yellow	Door Positions Sensor N.C.

※ Please refer to P1 for maximum load of monitor output
Please connect with RELAY if exceeding its maximum load to prevent damage to the unit.

【Monitor Output】

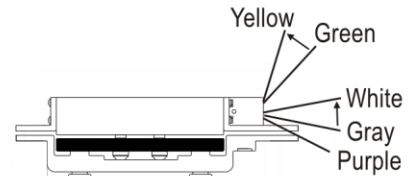

※ Lock :
Lock status output is COM.&N.C.
Door position output is COM.&N.C.

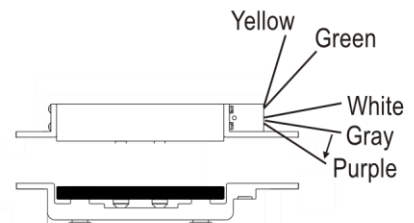

※ Unlock :
Lock status output is COM.&N.O.
Door position output as open circuit.

Wiring Diagram

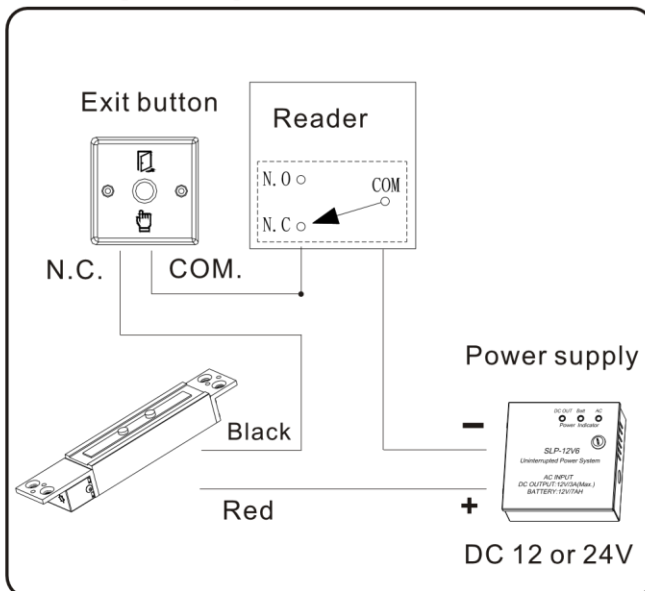

Panel Diagram

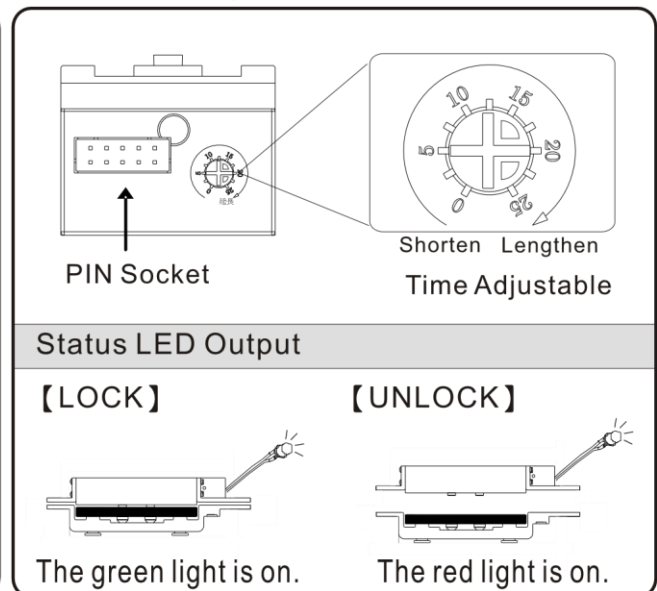

Please check before installation:

1. Please make sure the inner width and depth of door frame and door leaf (hollow metal door) are wide and deep enough to install the lock. Make sure the closing position of the door leaf is at the accurate place to enable the shear lock to lock accurately. Door closer is able to place the door leaf's closing position back to the accurate place to avoid other factor such as wind.
2. Minimum 900mA@DC12V/24V of current is required to activate shear lock. When it is locked, current will drop to 220mA@DC12V or 190mA@DCV24V. Therefore, current has to meet the standard of 1A and above to supply to the shear lock.

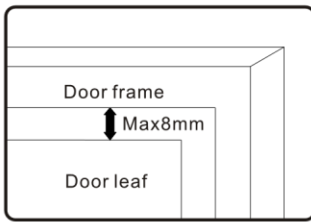

Maximum gap of 8mm

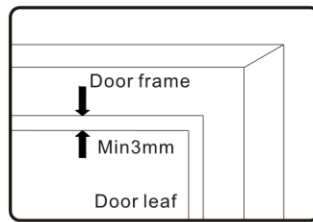

Minimum gap of 3mm

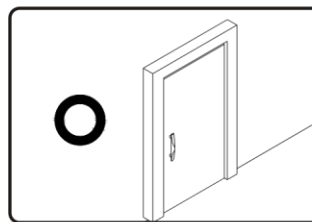

Fixed position of door leaf

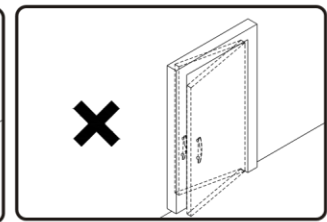

Door leaf's position is not fixed.

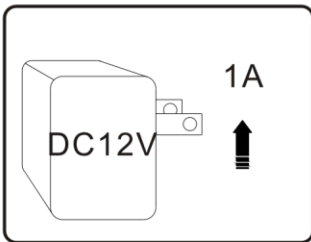

Minimum current of 1A@DC12V

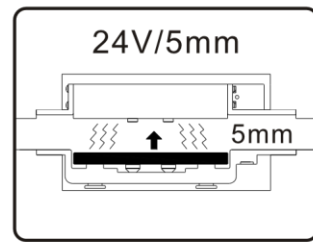

Maximum Magnetic distance

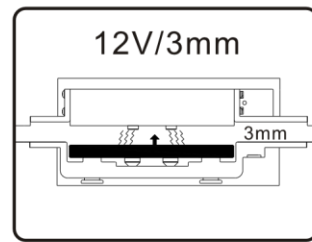

Maximum magnetic distance

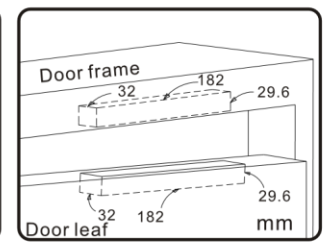

Minimum installation space

Fixed holes: (Installation of the lock and screws are different for solid doors and hollow doors.)

A: Solid door (A represents solid door's fixed screw holes)

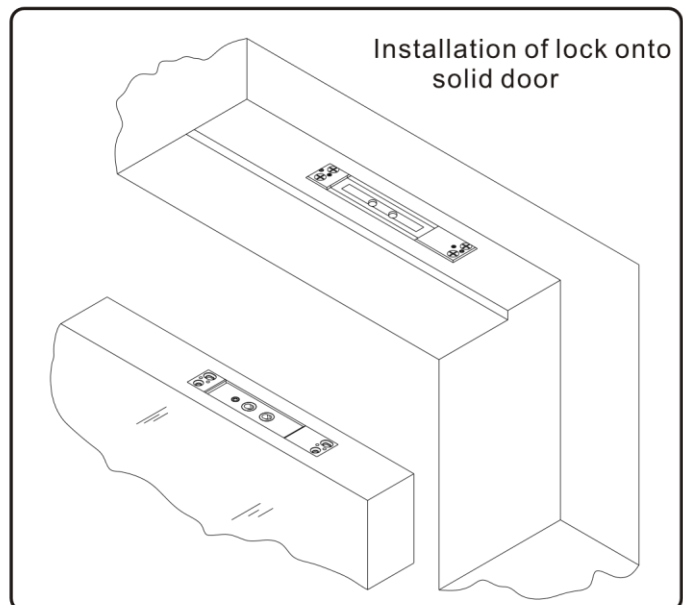
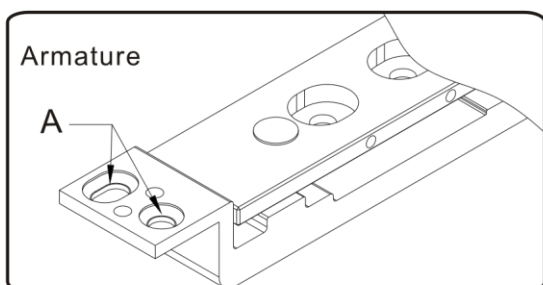
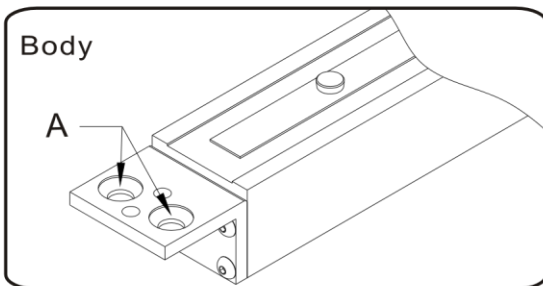

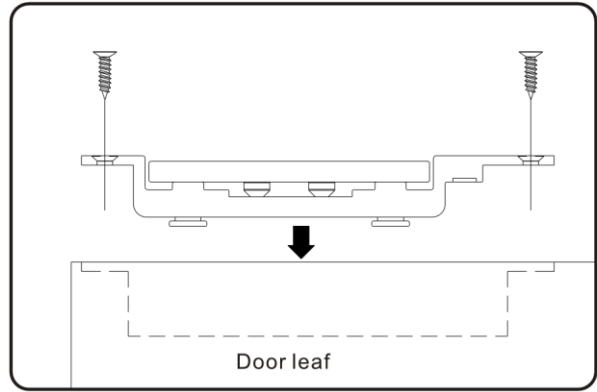
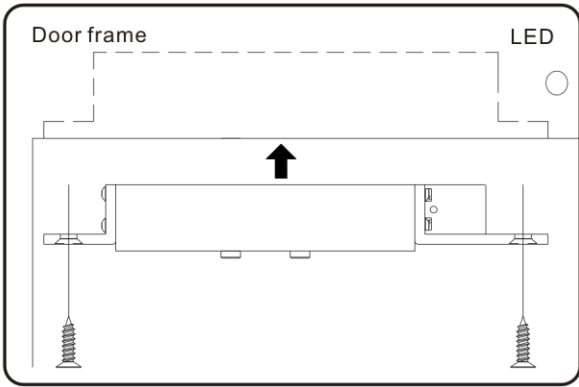

B:Hollow door (B represents hollow door's fixed screw holes).

Example 1:When the distance between the door frame and the door leaf is too small.

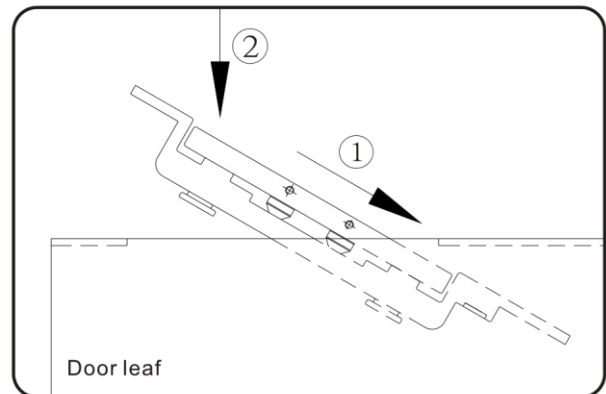
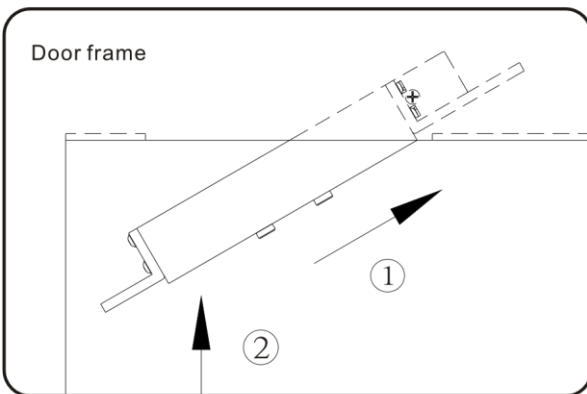
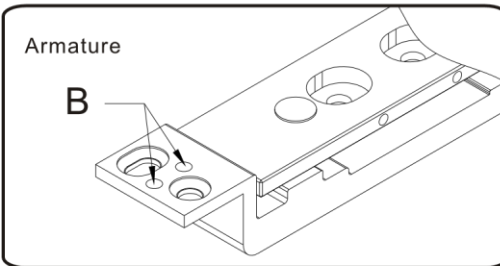
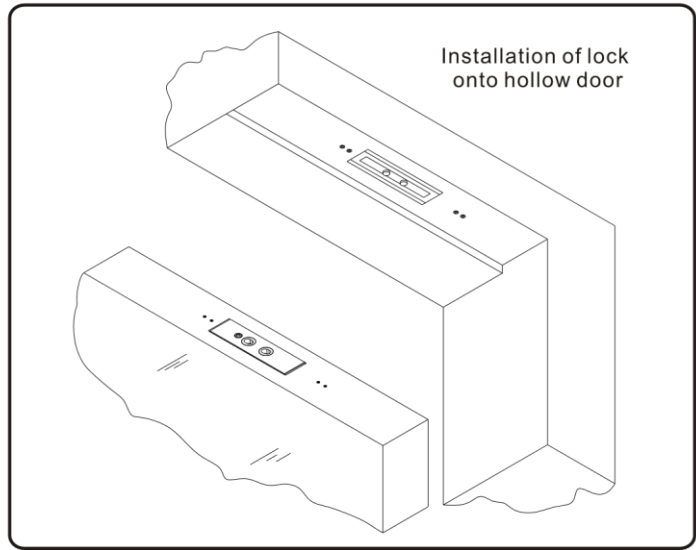
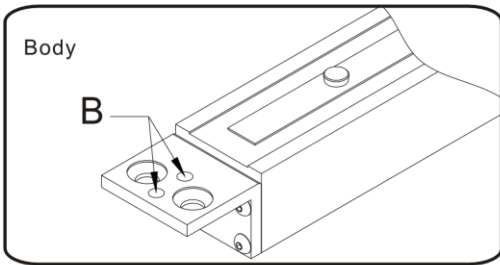

2:Use of shims

Installation of lock with template.

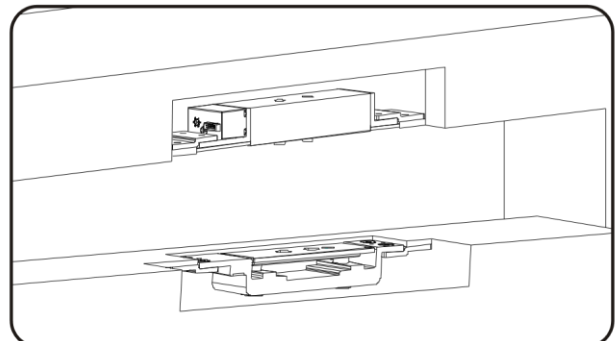
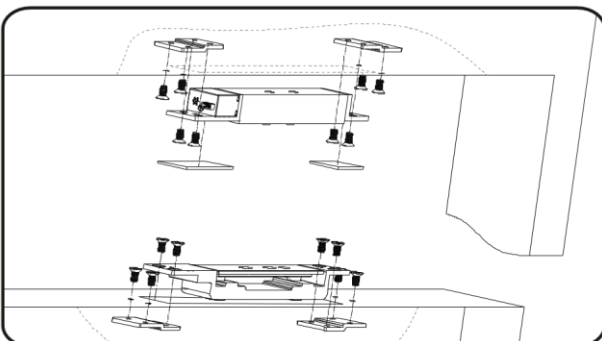

Installations:

☞ Step1: Make sure its installation position.

Diagram A: Install on the side of the door.

Diagram B: Install on the top of the door.

Diagram C: If it is stalled on the side of the door use a wrench to take out the springs and replace them with the springs provided from the screw kit.

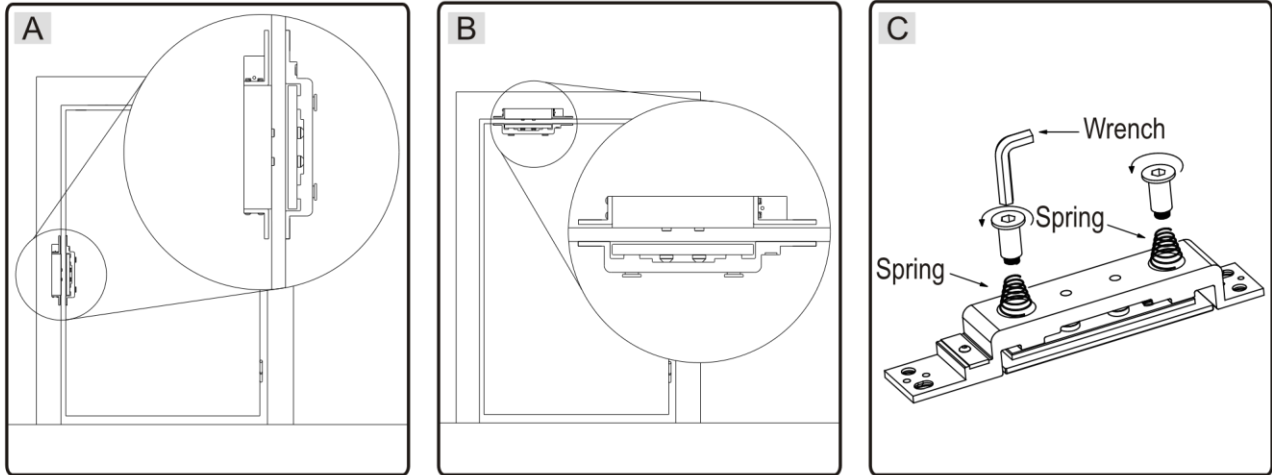

☞ Step2: Glue sticker

Please make sure both top and bottom sticker's position lines are placed in alignment.

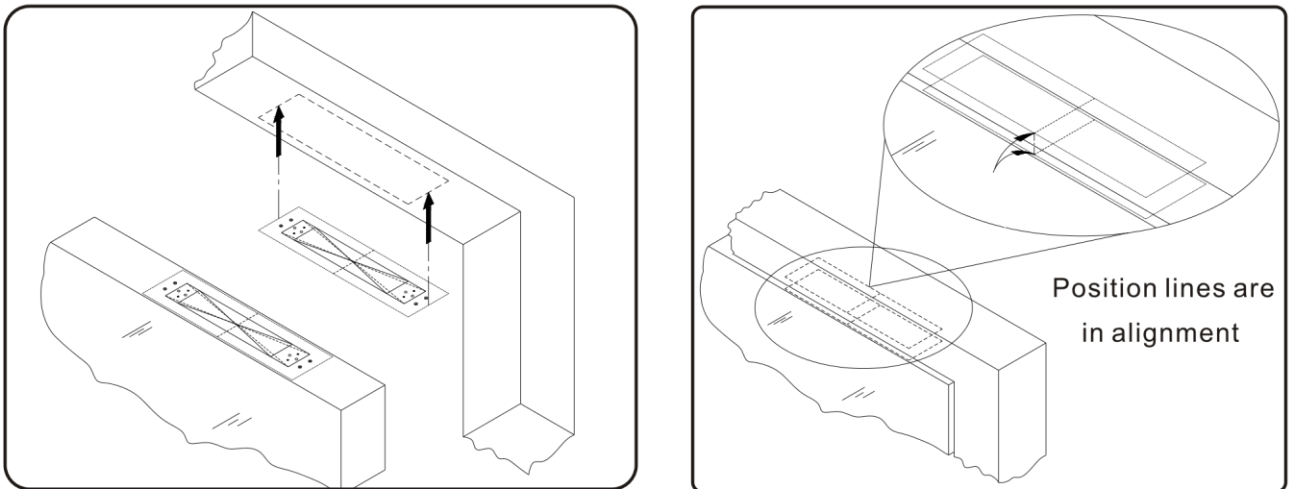

☞ Step3: Cut or Knockout

Cut (metal frame) or knockout (wooden frame) and drill a hole on the door frame for the indicator light next to the lock.

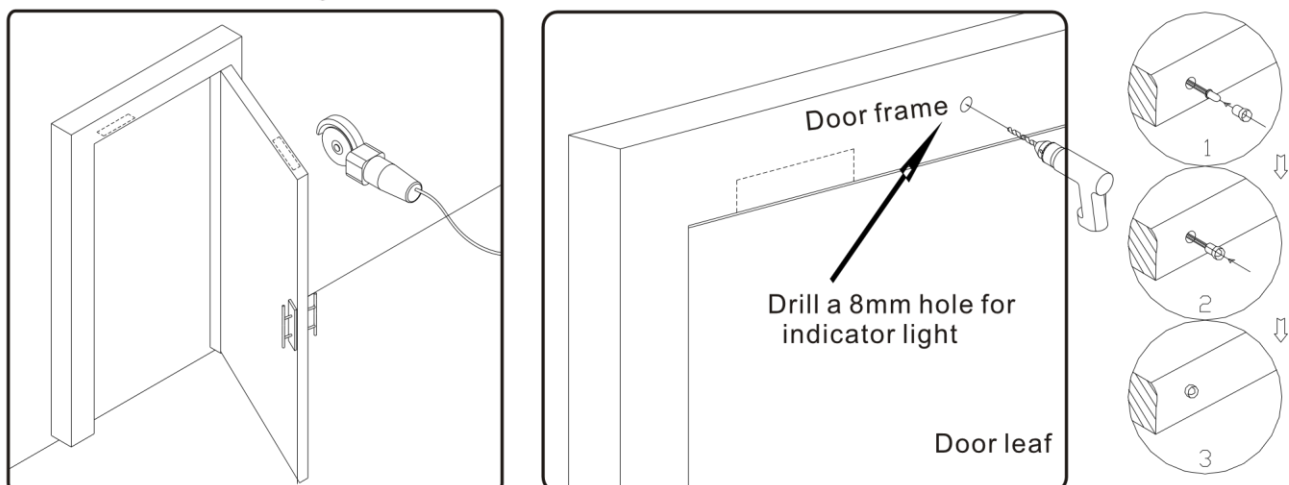

Step4:Wiring

Install the indicator light at the door frame and connect 5PIN connector with other wires. (Please refer to P2 for connector points)

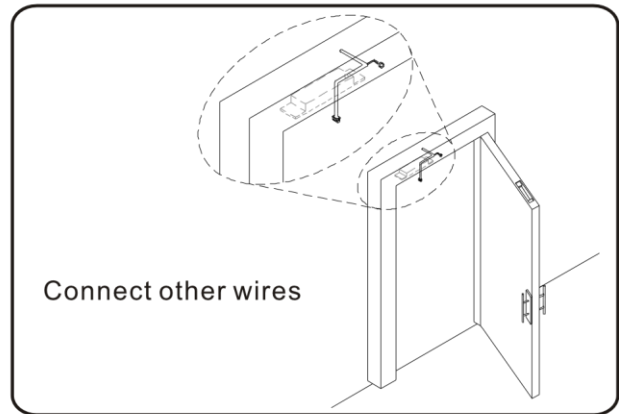
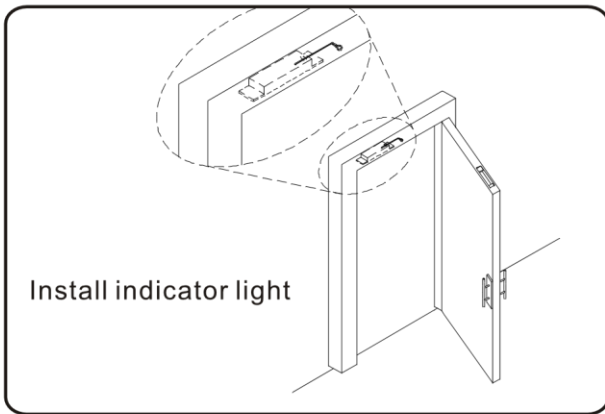

Step5:Fixing the lock and the armature

Connecting all wires to shear lock body. Adjusting required door open delay time and finally fixing both lock and armature.

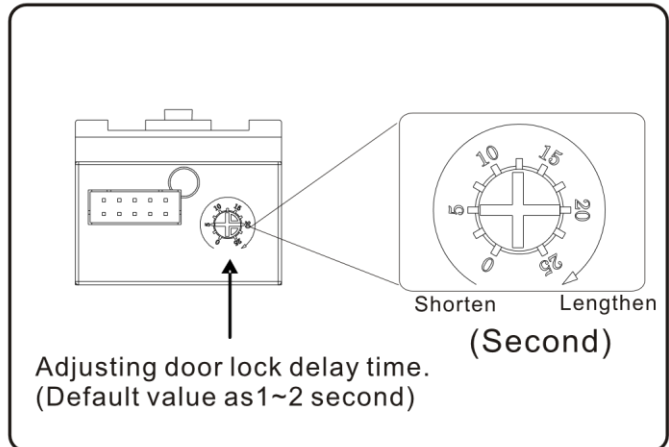
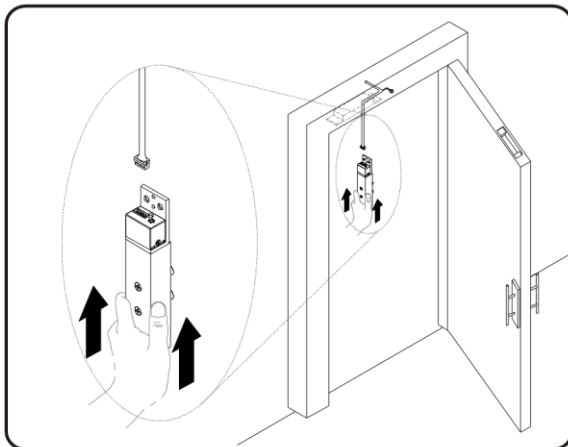

Step6:Current and fine-adjusting

Turn on the power and close the door to check if the lock is functioning properly. Please fine-adjust the armature if it is unable to lock properly. Please refer to Trouble Shootings for other problems.

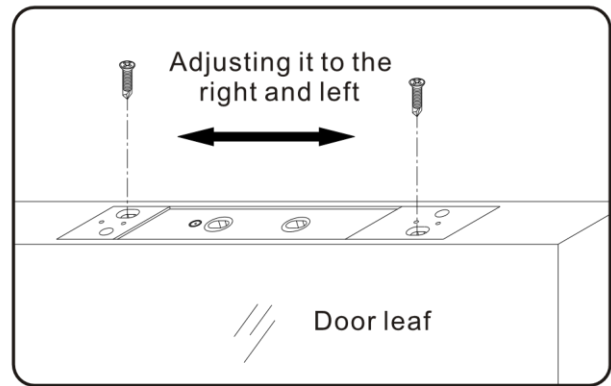
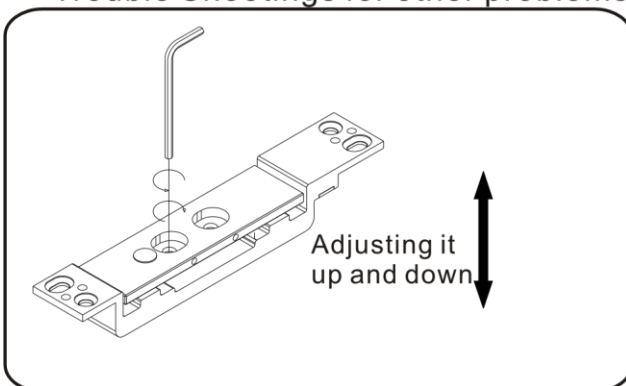

Notice

Maximum magnetic distance between the armature and the lock body is 3mm @12V or 5mm@24V. Use an Allenkey to adjust the armature. Please make sure the distance between the armature and the lock is even and not tilted or uneven.

Optional Brackets

Use an optional BR-12000 bracket to mount the lock if the width or the dept of the 12000 door frame or door leaf is not enough.

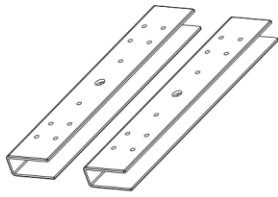

UB-12000

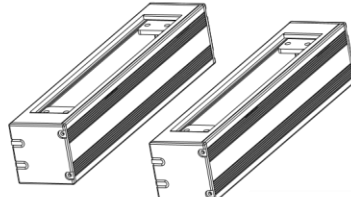

BR-12000

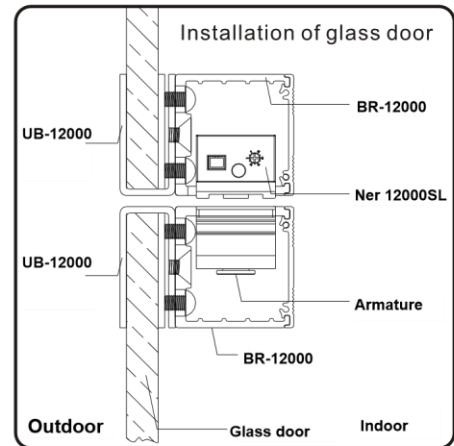

Glass door (frameless)

Mount the lock unit into the door frame. Use an optional BR-12000 bracket to fit the template. UB-12000 glass clip is able to fix glass door with thickness of 9-13mm.

Half-Surface Mount

The electromagnetic lock is mounted into the door frame, use the BR-12000 bracket to install armature.

Surface Mount

Use the BR-12000 bracket to install both the electromagnetic lock and the armature.

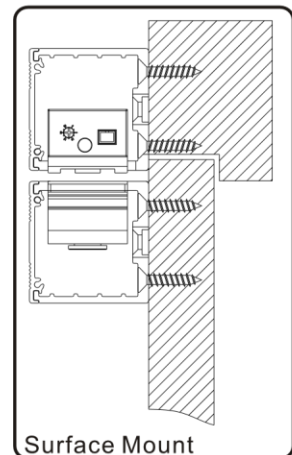
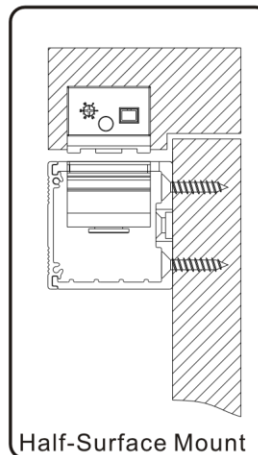

Trouble Shootings

Unable to lock

Check the power supply. Check the magnetic range (3mm @ 12V or 5mm @ 24V) between the armature and the lock body. Use an Allenkey to adjust the armature's screws if it is exceeded the maximum distance. Please make sure the distance between the armature and the lock body is even and not tilted or uneven.

Lock and release repeatedly

1. Please check if both positions are matched when the door is closed according to the requirement of step 2.
2. Please check the power supply.
3. Please check if the distance between the armature and the lock is even and not tilted or uneven.
4. Please check if it is exceeded the maximum magnetic distance.

Lock and release repeatedly before the door leaf is back to the closing position

Adjust lock delay time or adjust door closer ◦

Maintenance of the lock

1. Please keep both lock body and armature out of dirt or dust to avoid poor magnetic force.
2. Some environmental problems (such as at the seaside) may cause the rust of metal. Apply some lubricant oil such as WD-40 in the lock body to prevent from rust.

Mounting brackets UB-12000 & BR-12000 for magnetic lock Ner 12000SLp

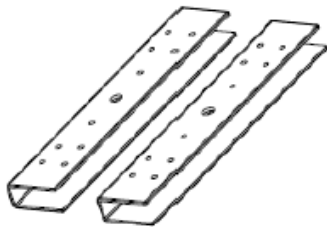

UB-12000

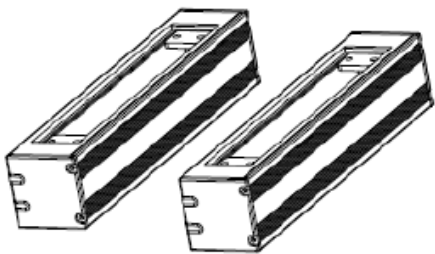

BR-12000

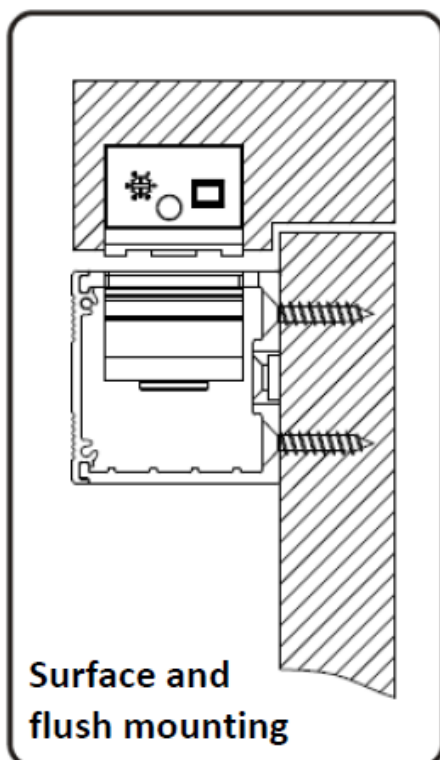
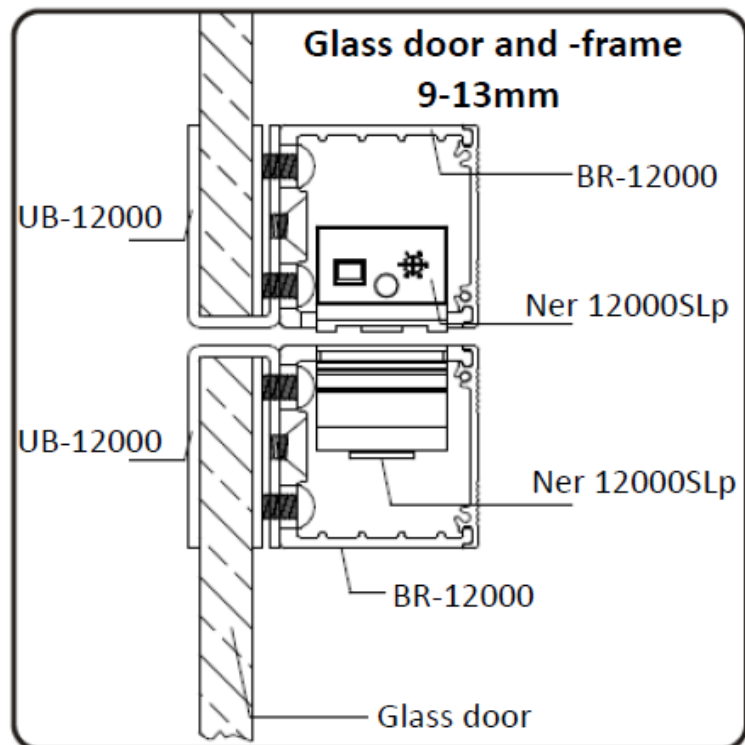

**Surface and
flush mounting**

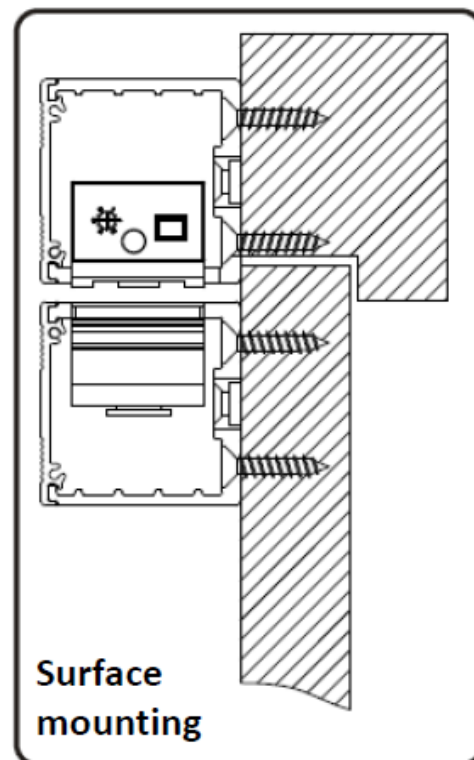

**Surface
mounting**