

Ovimagneetti Ner 5000LR

(Tilatieto+ Led)

Pitovoima	Yli 5000 N (1 kg = n. 10N) ei jälkimagnetismia.		
Rakenne	Anodisoitu alumiini		
Mitat	Magneetti	265x 71x 40mm	
	Vastarauta	185x 60x 13 mm	
Syöttöjännite/ Virta	12VDC/ 480 mA 24VDC/ 240 mA.		
Rele ulostulo	Potentialivapaa vaihtokosketin 0,1A/ 30 VDC.		
Led	Paikallisnäyttö oviympäristössä.	Vihreä:	Lukitus kiinni.
		Punainen:	Lukitus auki.
	Vastaraudan tunnistus perustuu Hall-ilmiöön, josta saadaan tilatieto esim. valvomoon.		

HUOM!!! Syöttöjännite tehdasasennus 24VDC
Muutettavissa 12VDC:ksi oikosulkusillan asetuksella.
Ohjaus ja hätäavaus (+) johtimen kautta!!!

Magneetti

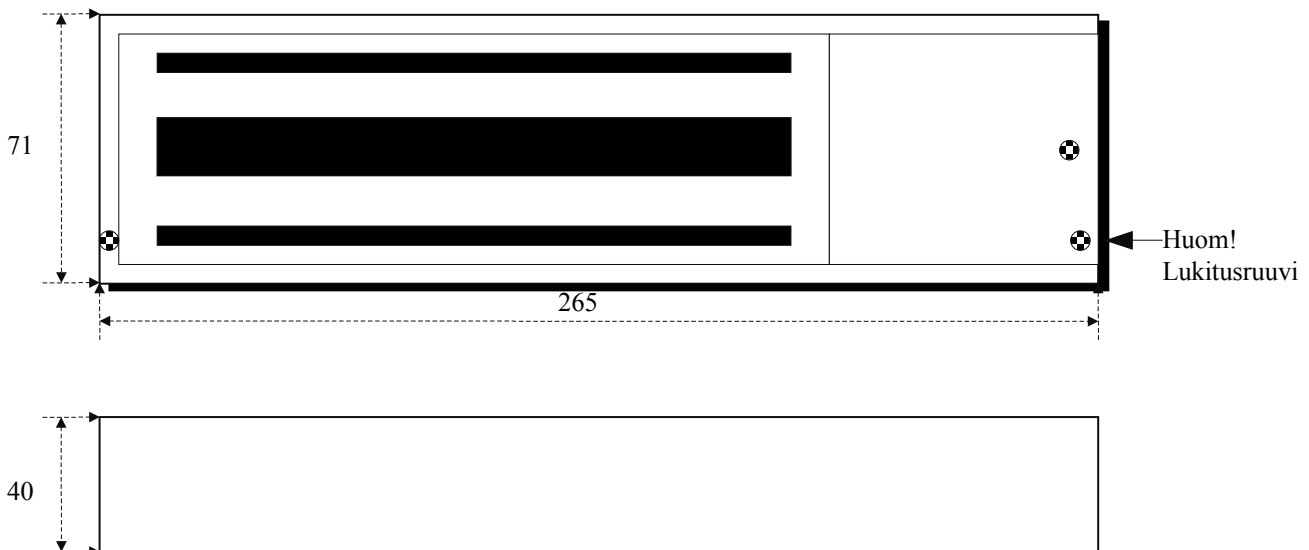

Vastarauta

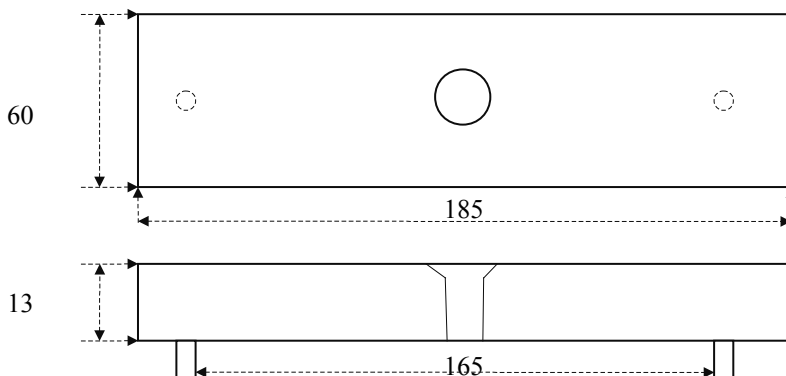

Kytkenä

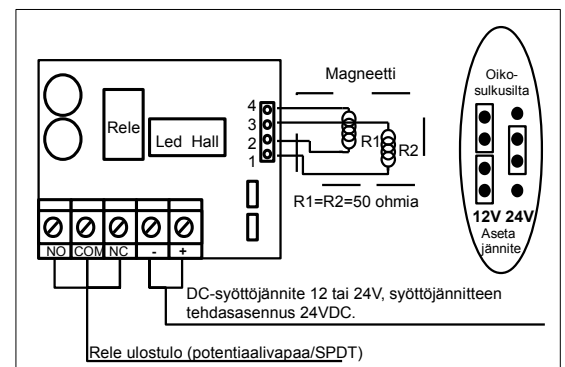

ASENNUKSEN PERIAATEKAAVIO

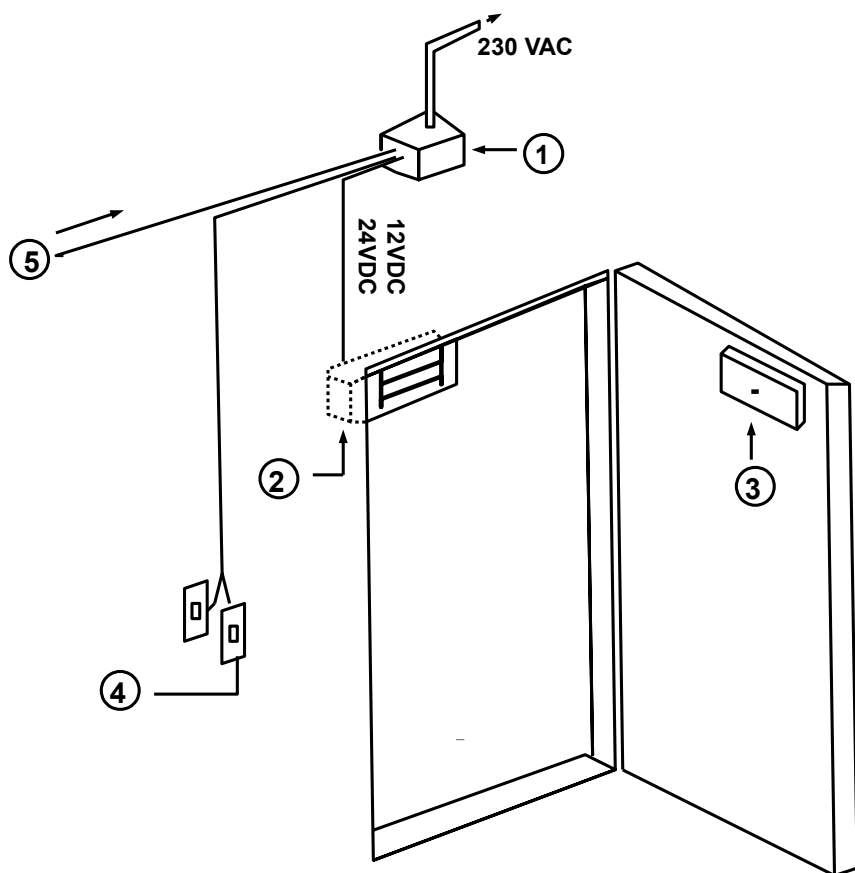

1. Jännitelähde
2. Magneettilukko
3. Vastarauta
4. Ovikohtainen aukaisupainike, kortinlukija tms.
5. Keskitetty ovenohjaus esim. valvomosta

VASTARAUDAN ASENNUSOHJE

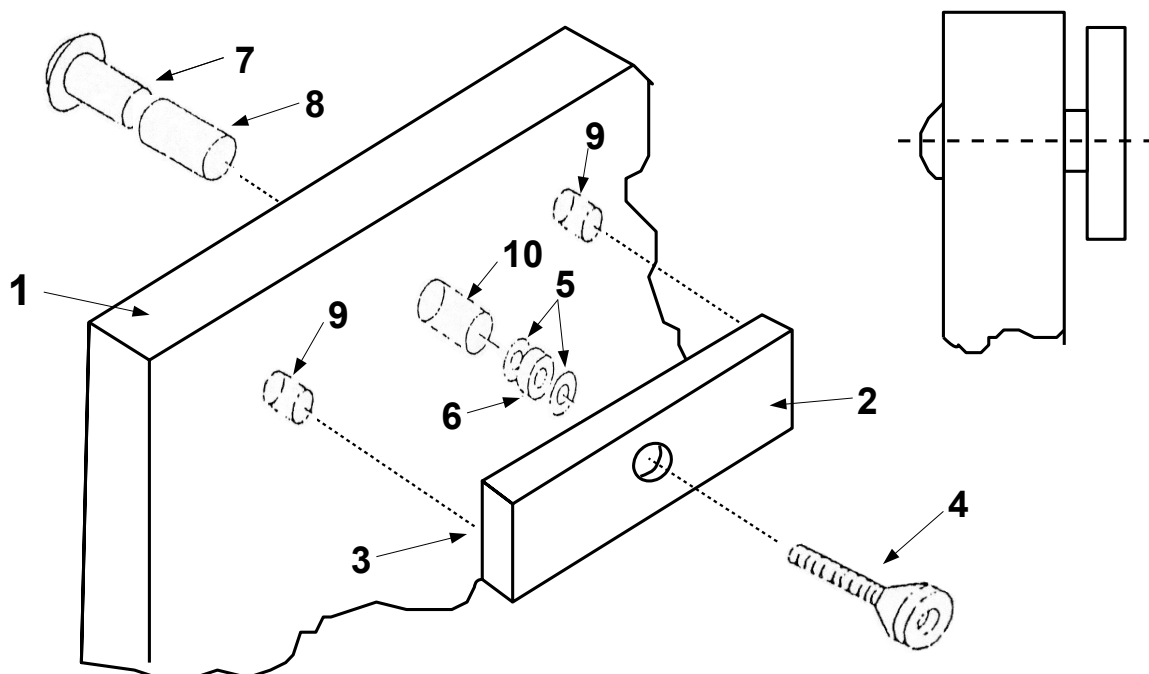

1. Ovi
2. Vastarauta
3. Vastaraudan ohjaustapit
4. M8 pulitti kumilla
5. Aluslevyt
6. Kumiholkki
7. Mutteri holkilla
8. Oviholkki
9. Reikä ohjaustapeille $\varnothing 6\text{mm}$
10. Reikä oviholkille $\varnothing 16\text{mm}$

HUOM! Vastaraudan asennus vaihtoehtoisesti metalliprofiiliin esim. niittimutteri M8 avulla.

Nerival Oy

Electromagnetic Lock

User Manual

CE FC RoHS

Read the manual before usage and keep for future reference.

Model	Size(unit:mm)	Voltage	Current	Holding Force	Lock Signal	Door Signal
Ner 5000LR	265L*71W*40H	12/24VDC	12V/480mA 24V/240mA	500kg(1200Lbs)	Yes	No

2. Application Range

1. Door Types: Wooden door, Glass door, Metal door, Fireproof door.
2. Control Mode: Building intercom system, Access control system.

3. Note

1. Using powerful power supply, output voltage should be $DC12V \pm 10\%$, cable $> 0.75mm$.
2. Don't hurt the galvanization layer during the installation.
3. Ensure the mounting plate well attach to the lock body.
4. The rubber ring must be added between armature plate and door leaf, don't fasten the screw tightly, keep the rubber ring elastic.
5. Don't welded the mounting plate to the door, or will effect the lock.
6. Clean the slushing oil with cloth, don't use alkaline or pungent cleaner.

4. Wiring of Lock

1. 12V-DC input:

Positive pole of 12V-DC connect to the terminal marked with “+”
Negative pole of 12V-DC connect to the terminal marked with “-”
Ensure the Voltage Selector is switched to 12V-DC.

2. 24V-DC input:

Positive pole of 24V-DC connect to the terminal marked with “+”
Negative pole of 24V-DC connect to the terminal marked with “-”
Ensure the Voltage Selector is switched to 24V-DC.

3. Wiring of Door-State Detector

The overload current of relay contact is 1amp. when the input is 24VDC, overload is strictly prohibited. Connect the normal-open circuit to the COM and NC for getting switch-over signal. But connect the normal-close circuit to the COM and NO for getting switch-over signal.

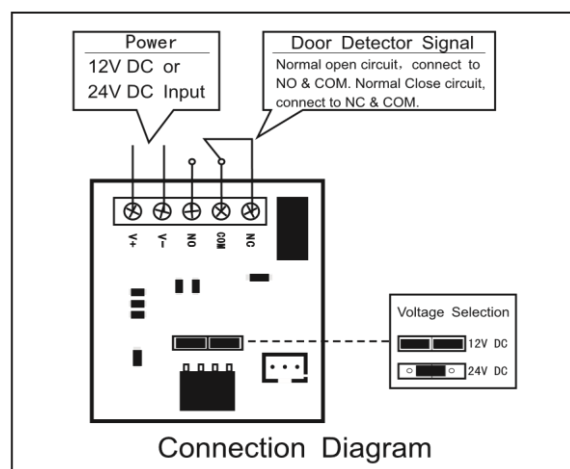

Note: Please use the 12V-DC input if the lock has not special annotate. The overload voltage will damage the lock.

5. Disassemble Procedure

Disassemble the cover and band before installing the lock.

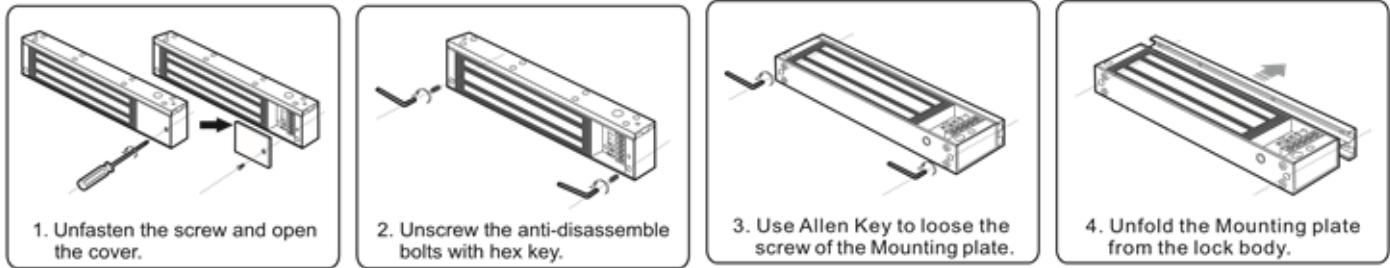

6. Standard Mounting Method

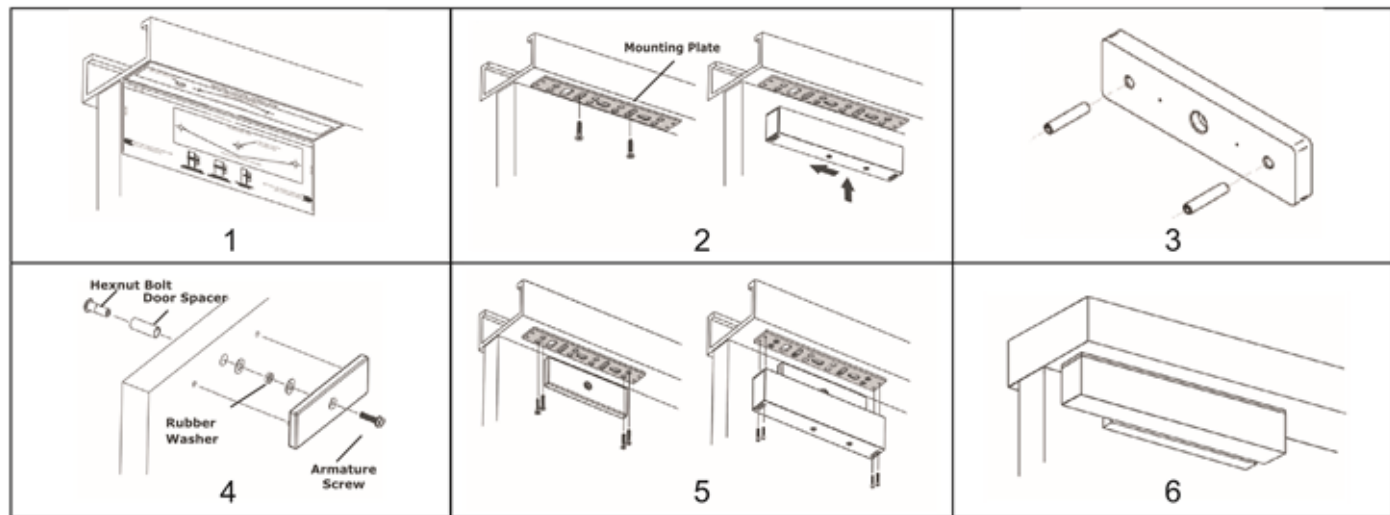

- Use the supplied template to determine the correct location and size of mounting holes for both the door and frame header. Ensure that the door opens away from the Maglock. In the case of a single door, the Maglock is positioned as close as possible to the vertical section of the door jamb. Drill door and frame as indicated.
- Loosely install the mounting plate using two of the supplied Philips head mounting screws in the elongated slots. Attach the Maglock to the mounting plate.
- Using a hammer, lightly tap both roll pins into the armature plate until they are secure.
- Before installing the Hexnut, the hole in the door may need to be drilled or tapped. Refer to page 2 for this information. Using the components shown in the image to the right, mount the armature to the door. Make sure that the armature plate is not over tightened and that it is installed as shown in the following diagram. The armature plate must be free to self align with the door.
- Ensure the armature and magnet are aligned. Adjust the mounting plate to suit and then drill the appropriate sized holes in the door header for the remaining attachment screws.
- Close the door to test holding force. The angle between armature plate and magnetic lock can be adjusted by adding or reducing washers.

7. Bracket Mounting Method

