

OPERATING INSTRUCTIONS

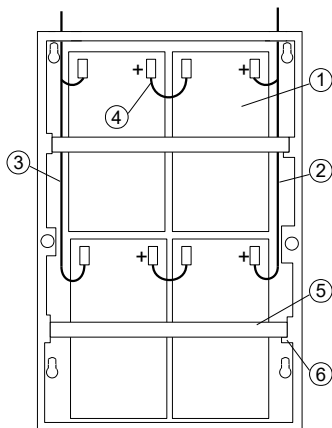

Type	PB24
Voltage	24VDC
Battery capacity	14Ah

Installation

1. Batteries
2. Cable red (+)
3. Cable black (-)
4. Cable yellow
5. Mounting bar for batteries
6. Locking plate, bend to open/lock

Specifications

Batteries	4 pcs Powersonic 7.0Ah
Enclosure	IP21

BATTERY CONNECTION 24V 14Ah

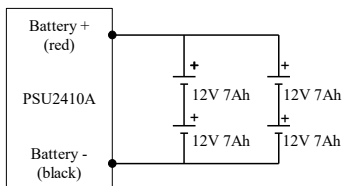

Battery follow-up

Installation date _ _ - _ - _

Battery change _ - - -

Battery change _ - - -

Battery change _ - - -

Battery change _ - - -

Battery change _ - - -

RECYCLE USED BATTERIES!

WARNING

Disconnect mains from charger unit before connecting battery wires.
Batteries contain high energy, do not short circuit.